



Nokia Siemens
Networks

A vision of tomorrow's connected world

My services anywhere

A White Paper on converged networks
and flexible business models

Resume

This paper outlines the Nokia Siemens Networks vision of tomorrow's connected world. It looks ahead to 2015 and considers the challenges and opportunities that arise when there will be a global community of around 5 billion people communicating, working and socializing using broadband connectivity, mobile devices and innovative Internet applications.

Predicting the future seven years out is challenging. Change might appear to be the one constant in today's environment, nevertheless there are a number of generic parameters that help us define the market, the network architecture, and the underlying technologies.

The key components are known as well as the synergistic interactions that are needed to meet that fantastic opportunity. This paper has therefore been created to support today's decision makers as they guide the teams that are building or migrating their network in order to meet tomorrow's challenges and realize the fantastic opportunities.

Table of Contents

1.	Introduction.....	4
2.	Tomorrow's connected world.....	5
2.1	The connectivity domain.....	6
2.2	Factors that drive traffic.....	6
3.	Trends	7
3.1	My Services Anywhere.....	7
3.2	Factors that drive traffic	7
3.3	Opportunities abound.....	9
4.	Network Architecture Vision	10
5.	Connectivity Domain	11
5.1	Flattening in access and aggregation	12
5.2	Unified transport network	13
6	Embracing the Internet	14
6.1	Session control and interlligent IP Edge.....	14
6.2	Identities and trust.....	14
6.3	Internet challenges	15
7.	Application Domain	16
7.1	Service Delivery Framework	16
7.2	Operation and Business Support.....	16
8.	Smart connectivity.....	17
9.	Conclusions.....	18
10.	Glossary.....	19

1. Introduction

Communication in 2015 will be amazing: we'll employ cool, mobile devices whose performance and capacity are comparable with today's high-end computers. DSL or fiber broadband connections will bring high-definition home cinemas online and high-speed, always-on connectivity to the Internet will facilitate the use of other innovative applications and services. These will employ the best available connection – wireline or wireless.

To imagine the new possibilities let's take a look at an augmented reality application that was derived from the Nokia research project MARA . You're on a sight-seeing tour of the old town part of a city and you see an interesting building. In order to get some information you align the camera of your mobile phone, which is currently connected via LTE to the Internet and discover that it's an art museum. Based on additional location information derived from the integrated navigation system and/or the network, the display gives you a short description of the museum. It may also include information about the architecture and the exhibitions.

You go into the building: the entry fee will be charged to your service provider via a simple double-click. The device will also make a seamless transfer to the museum's wireless LAN, because it's the best available service, and offer an interactive tour. The requisite technologies and services that provide this kind of augmented reality experience are known, but this is just one example of the way they could be deployed. Tomorrow's connected world will be full of location-based services as well as feature-rich applications.

This world will be enabled by those powerful devices as well as always-on, smart, secure connections to the Internet.

¹ MARA was featured by MIT Technology review and listed as one of their 10 emerging technologies for 2007

2. Tomorrow's connected world

Market forecasts indicate that around 5 billion people will form global, end-user communities that employ numerous voice, video, messaging services as well as innovative Internet applications. Mobility and Internet connectivity by 2015 will be taken for granted and the various communities will be online around the clock and around the world. By that date cellular subscriptions will also hit 5 billion, as indicated in figure 1. Right now many of these users connect to the Internet over a high-speed service, e.g. EDGE or HSPA, and in future LTE will be employed.

The main growth in mobile subscriptions will come from emerging markets such as China and India and we foresee widespread use of Internet connectivity from the beginning. Because mobile phones are much cheaper than PCs this is where communication and collaboration will start in these markets. This will be followed by applications that provide health, education and administration services for remote areas. The growth of wireline broadband access (Figure 2) will also facilitate usage of bandwidth-hungry applications like IPTV for more than 2 billion people by 2015.

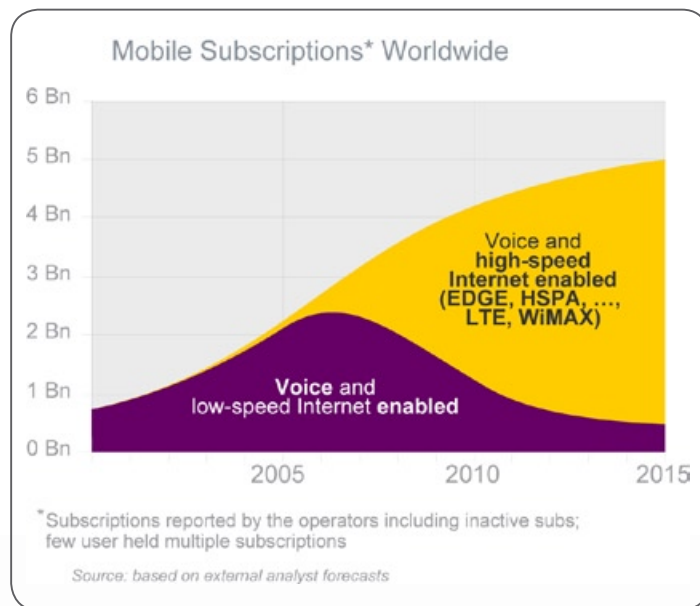

Figure 1: Worldwide mobile subscription forecast

By 2015 applications will be mainly hosted on the Internet and the role of user communities, social networks, content sharing and collaboration will have increased. In addition, convergence will be complete: fixed and mobile networks will have merged and revenue streams will come managing the end user experience and by leveraging identity and location data. These converged networks will therefore broadly divide into connectivity and application domains. This development is covered in section 4.

2.1 The connectivity domain

Different wireless and wireline interfaces will be employed. They will reflect the data rate, mobility and reach requirements of the various applications and the different spectrum allocations. As illustrated in figure 2, cable, copper and fiber will provide fixed line connectivity in the home, but around 2010 WiMAX will be a viable wireless alternative. The wireless air interfaces will be EDGE, HSPA and LTE. The key connectivity challenges are: (a) reduce OPEX; (b) accommodate a 100-fold increase in traffic; and (c), cope with declining ARPUs. This will be realized by deploying more efficient access and transport technologies and self-management methods. The connectivity domain will enable services to be transferred seamlessly from one access network to another and, when applicable, from one device to another. "My Services Anywhere" will be the mobility paradigm, enabled by the ability to employ any access network, on any device, anywhere, at any time.

2.2 The application domain

This domain will become a huge ecosystem, one that's driven by the accelerated introduction of new services, applications and business models. From the operators' perspective, the increasing influence of third-party service providers and fierce competition will drive the need to move from the "walled garden" model to that of open business systems. Applications will be network independent; they will support converged networks as well as the Internet; they will be based on a robust service delivery architecture and network-independent identity management. Streamlined and centralized network management will support new business models and enable revenues to be collected from both subscribers and third-party service providers, the latter via revenue sharing. Efficient life cycle management for service

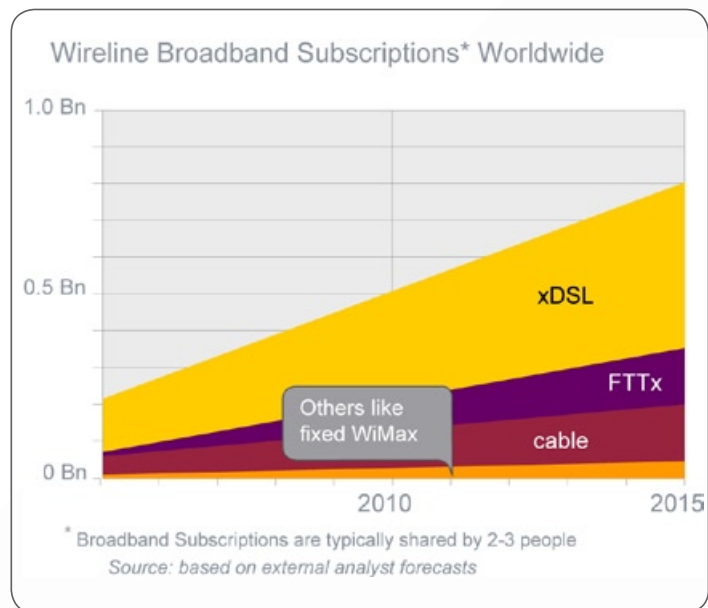

enabler and application software components is critically important, as is an effective linkage into the business process layer. This is required in order to bundle communication services with advertisements, content distribution and other business domains. Nokia Siemens Networks and its global partners cover all mainstream technologies and around 100 research projects are driving leading-edge solutions. A key objective is to facilitate the ability of our customers to deploy the new architecture and the associated solutions and thereby meet the diverse and demanding needs of the market.

Figure 2: Worldwide fixed broadband subscription forecast

3. Trends

When we look at the ongoing developments it's clear that access to communication services will be available practically everywhere in the world and that the benefits apply to the majority of the population. However, that objective can only be realized in the emerging markets if the mobile devices and the services are affordable. This is a challenge for the industry but it also represents a huge opportunity.

Chip developments will continue to reflect Moore's law, thereby reducing cost and enabling more functionality, which in turn enables devices to access more services. Increased computing power and memory resources also allow mobile devices to run the same applications as laptop PCs. And in the home, laptop / desktop PCs and entertainment systems will be connected with each other and the Internet. In the home, various appliances, laptop/desktop computers, and entertainment systems will be connected with each other and the Internet.

Technology continues to drive the development of more and more devices, both multi-functional and highly specialized. These devices will be broadband-enabled and they will support multiple access types, both wireline and wireless. Access will be determined by "best connected", i.e. the optimum service will be selected. The process will be transparent and be based on access policies. All devices will have direct access to the Internet and devices will continue to get more functionality.

3.1 My Services Anywhere

The Internet model will prevail: applications will be access and device agnostic. "My Services Anywhere" will become the paradigm and using a service will be as easy as making a telephone call. Access to community services, peer-to-peer applications, a single phonebook and file systems will be ubiquitous. Technology will be used to hide network complexity and provide compelling user experiences, thereby boosting traffic and enabling new revenue streams.

The "My Services Anywhere" paradigm comprises:

- User mobility; same services on PCs, TVs with set top boxes and mobile devices
- Terminal mobility; transparent "best connected" access combined with seamless handovers to alternative networks
- Service mobility; same services employed on all networks, e.g. GSM, UMTS, LTE, xDSL, PON, Wi-Fi and WiMAX.

3.2 Factors that drive traffic

Socio-economic trends and developments like migration, dwindling energy resources, environmental issues, and the increasing familiarity of the people with computer-aided communication techniques have facilitated the use of virtual interaction (Flickr™, YouTube™) and virtual identities (Second Life™). This will result in wide adoption of Internet services based on Web 2.0 and upcoming support technologies.

In addition there are other factors that impact on the industry and new network architectures. These include: fixed and mobile regulation, spectrum refarming, expensive and scarce energy resources, environmental issues and the emergence of citizen networks.

Strong subscriber growth should compensate the effect of falling ARPUs in mature markets and low-entry ARPUs are required for the emerging markets.

Call charges show a double-digit percentage decline year-on-year. End users prefer mobile voice, a trend that is taking voice minutes away from the fixed networks. Mobile phones have become the preferred choice for most users. Many countries have more mobile than fixed telephone subscriptions and subscriber penetrations of over 100% in some markets. We expect the global voice market to be saturated by 2015.

Communication services contribute to the economy and our personal welfare. However, lower personal incomes and large populations in rural areas require new business models and new solutions that provide end-to-end connectivity. Most of the next billion new users will come from the emerging markets, but only when devices and services are affordable.

Industry consolidation is taking place, vendors as well as operators. The blurring of industry boundaries, the growing role of the Internet, and intensifying competition will result in new providers, partnerships and business models and walled gardens will be bypassed by the new business opportunities.

The Internet, however, has allowed brand-new players to enter the arena. Their focus is applications and content services, not networks. There are virtual mobile operators like Virgin mobile, application and content service providers like Google™ and ISPs like AOL™. The Internet allowed these companies to attract a worldwide customer base in a very short timeframe.

The revenue stream for operators comes from providing connectivity as well as real-time applications and those that require a high QoS. The new entrants provide innovative services like GoogleEarth™ or YouTube™ and their revenue stream is built around business models that offer free services. They leverage a fast-growing global customer base and realize revenue growth in other ways, e.g. focused advertising.



The Internet model will prevail and, as illustrated in figure 4, a huge ecosystem drives the introduction of new services and competitive business models. Walled gardens are coming down and being replaced by open business systems that support third-party revenue models. At the same time premium content and communities have a place in the value chain.

Figure 3: Convergence of upcoming devices

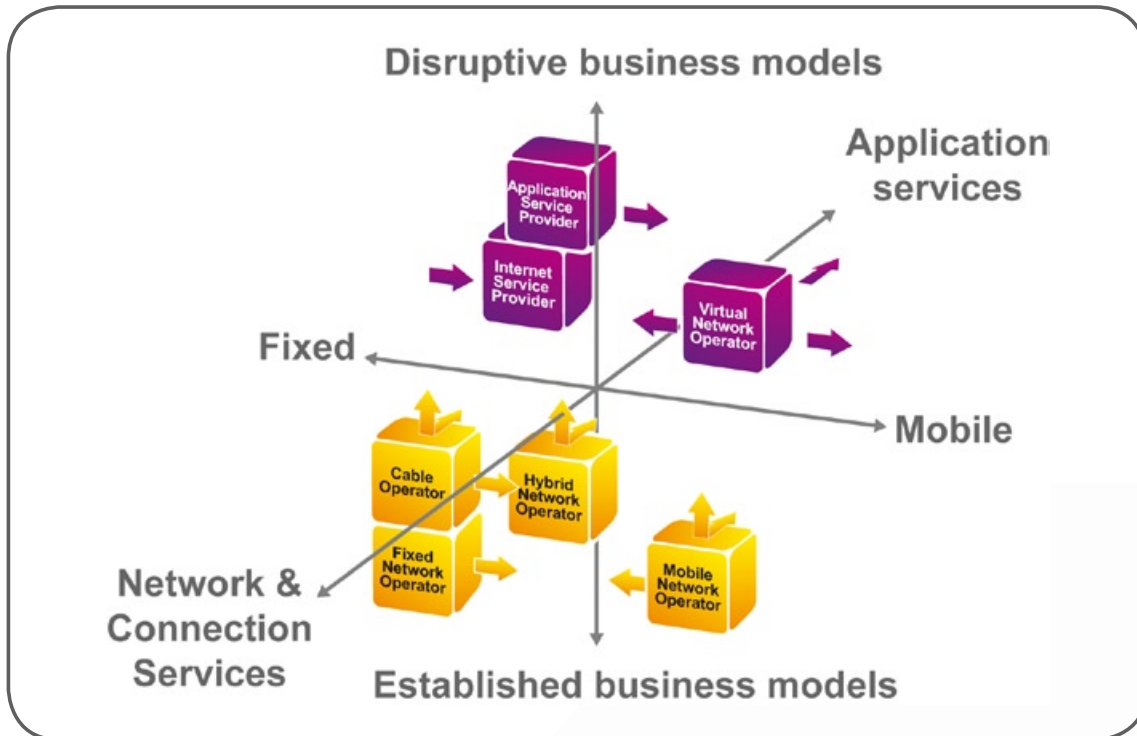

Figure 4: New business models enter a market that is increasingly complex and competitive

3.3 Opportunities abound

Operators are uniquely placed to leverage their business relationship with their customer base, e.g. they can cooperate with the new application providers and participate in additional revenue streams.

The life cycle of mobile phones and multimedia PCs is around two to three years. New devices are purchased because they support new technologies and services, which in turn enable new functionality. Thus the network operators' offer should focus on this opportunity.

Providing connectivity to these intelligent, powerful devices and delivering applications and services to end users has to be based on a network architecture that embraces IP- and Internet-technologies. In addition, the architecture must accommodate different access technologies and ensure that the applications become access agnostic.

There is no one-size-fits-all solution. A wide range of network technologies and support for a multitude of end devices is required in order to match needs and expectations. Nokia Siemens Networks, together with Nokia and other leading vendors, has the requisite technologies and products that meet the diverse needs of tomorrow's connected world.

4. Network Architecture Vision

Today's network architecture is very complicated: it's the result of interworking and integrating different legacy networks and the use of intrinsically different technologies. Fixed and mobile networks occupy separate domains and broadband is a relatively recent development. There are different network structures, network elements and operation and maintenance tools. Simplifying and converging these networks is required in order to realize a network architecture that will slash OPEX and reduce complexity. That is the focus of our network vision.

As illustrated, there is a logical separation of the connectivity domain and the application domain. In the case of Session Control, Intelligent IP Edge and Identity Management, these two domains meet and this creates opportunities for operators to bundle both domains into a cohesive offer. In addition, Operations & Business Support is common to both domains. The connectivity domain comprises the multi-access network as well as the transport and aggregation network.

A flat transport and aggregation network serves the multi-access network. All services will use the same core network and services will be differentiated at the edge of the network. The transport network will have three layers: optical transport, Carrier Ethernet and IP.

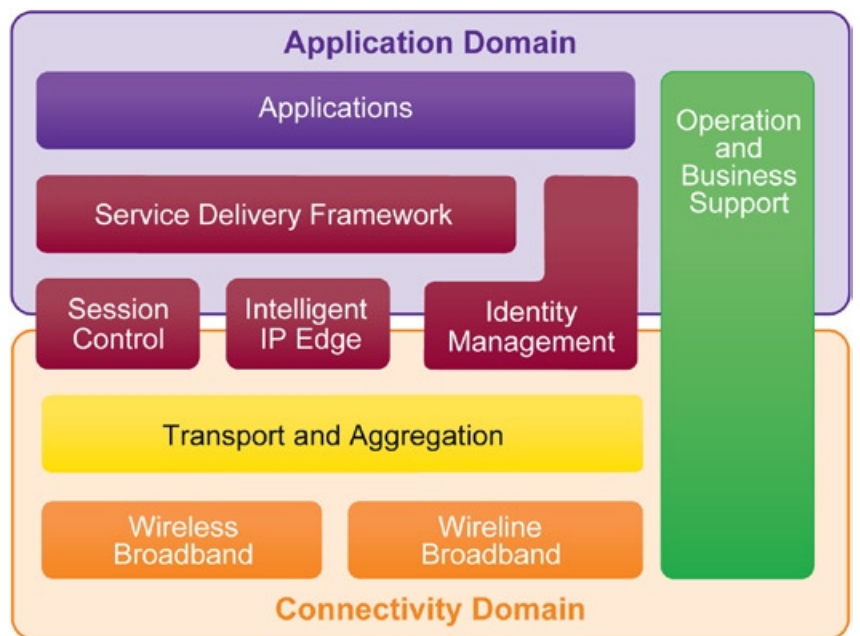

The key characteristics of the application domain are the convergence with IT and its separation from the transport layer and the connectivity domain. This is enabled by the layered architecture, open standardized interfaces and APIs. This is the space in which third parties can play. The access agnostic applications will be accessed using IP and most will reside in the Internet.

Session control and identity management are covered in sections 5.5 and 6.2 respectively.

Figure 5: This architecture separates the application domain from the connectivity domain, thereby allowing the network to adapt to new bandwidth requirements, to create new capabilities, and introduce new services much faster

5. Connectivity Domain

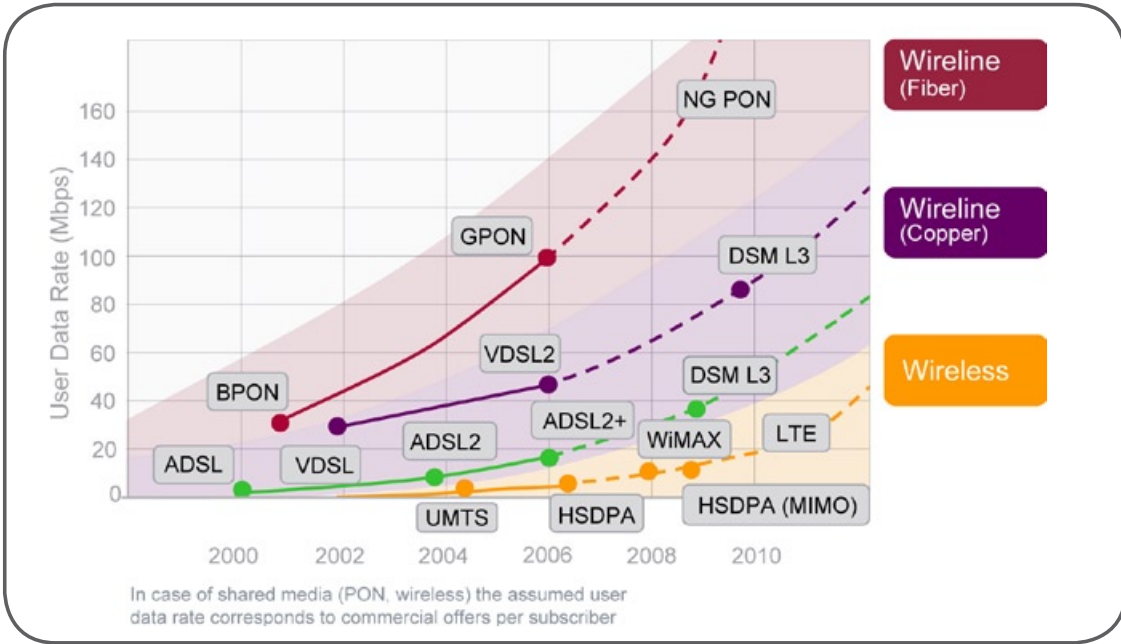

Figure 6: Bandwidth development of access technologies

Fixed broadband access will continue to offer higher data rates than wireless. Today's fixed user data rates are about 30 times that of wireless, and both have a similar evolutionary trajectory (see Figure 6). Bandwidth-hungry applications like high definition television will be best connected by passive optical networks (PON). The next generation PON (NG PON), which supports data rates of 10 Gbps, will significantly enhance today's capabilities in terms of bandwidth, coverage and scalability. Point-to-point fiber will be used to enable Carrier Ethernet connectivity for enterprises.

Advances in xDSL technologies like dynamic spectrum management will drive bandwidth towards 100 Mbps. This will enable the continued and optimum use of today's copper infrastructure. However, because of convenience and mobility, the predominant access technology in terms of subscriber numbers will be wireless.

Wireless data rates will match the performance requirements of most mainstream applications, but no single wireless access solution or radio technology can provide cost-effective wireless access in all scenarios and for all user needs.

In future, access will be provided by a system of heterogeneous wireless networks, which will enable the "always best connected" paradigm.

The main advancements in wireless access technologies include fast link adaptation, power control, beam forming, channel dependent scheduling, and multiple input/multiple output (MIMO). A common objective is to improve capacity through better spectral efficiency and more flexible spectrum usage.

Wireless broadband access using wireless LAN technologies are widely deployed in homes, enterprises and hot spots. Mobile WiMAX deployments offering mobile broadband services for wide area wireless coverage will start soon. These technologies, driven by IEEE standardization, will offer a competitive way of building the wireless Internet.

A consolidated and converged broadband backhaul network domain will evolve, whereby cellular or wireless user access is aggregated and backhauled via xDSL copper, microwave and/or fiber networks.

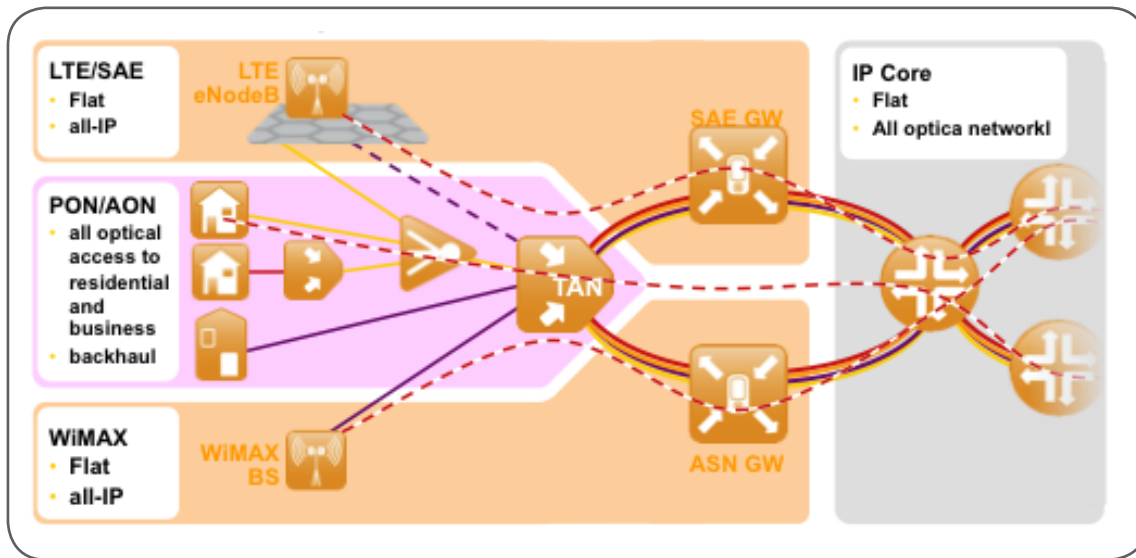

Figure 7: Flat access and aggregation in fixed and mobile networks

5.1 Flattening in access and aggregation

HSPA is widely deployed and data rates will be further enhanced by LTE: the 3GPP Long Term Evolution. LTE will offer mobile broadband services with peak bit-rates up to 100 Mbps or higher in certain scenarios. HSPA and LTE are driving the transition of mobile networks to an all-IP architecture based on 3GPP's System Architecture Evolution (SAE).

As illustrated in figure 7, the aggregation level will be simpler. Functional elements are being concentrated into a few powerful network elements. For example, we expect a new class of access nodes — the Terabit Access Node (TAN) — to replace traditional fixed access nodes. TANs provide significantly higher performance than today's nodes and this will enable the full integration of optical interfaces and IP edge functionality.

There is a similar development in the mobile access network. For example, LTE/SAE architecture framework will result in a flat, packet-centric network architecture. This means that today's network elements in the mobile data transport domain (RNC, SGSN, GGSN) will be collapsed and their functions redistributed. The resulting flat network architecture will be realized on the enhanced Node B (eNodeB) and the related gateway (SAE GW) in a new function split. This helps reduce latency and it also reduces OPEX. The same benefits are valid for the WiMAX and I-HSPA architecture.

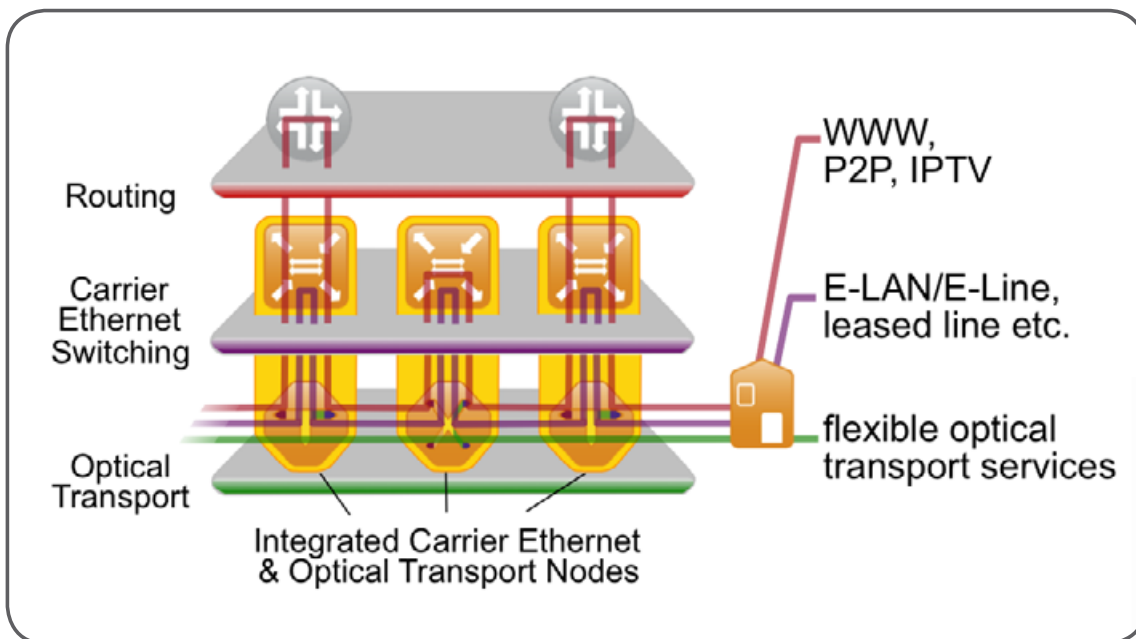

Figure 8: Multi-layer optimized optical transport network

5.2 Unified transport network

Tomorrow's transport and aggregation network will integrate today's different transport networks and enable the migration of current and future traffic onto a unified network. Handling traffic levels through to 2015 and beyond in a cost-efficient way, at high performance levels, requires flat, all optical networks.

Emerging technologies like software defined optics, 100 Gbps links, photonic lightwave circuits, new generation of optical fibers, and optical packet switching make the architectural vision feasible. The optical transport network of 2015 will be hybrid comprising transparent all-optical islands, connected by opaque nodes, with optical/electrical/optical conversion.

The metro and access parts of today's networks will converge into a single aggregation network that collects all the traffic and transfers it to the photonic core. Carrier-grade Ethernet will replace ATM as the dominant aggregation technology. IP routing functionality will be concentrated, while the core network will be flat and employ carrier-grade switching technologies. The resulting architecture will have three layers: Optical, Carrier Ethernet and IP/MPLS

CAPEX and OPEX are reduced by optimizing the interaction of these three layers, i.e. by applying the concept of multi-layer optimization (see figure 8). This technology simplifies traffic processing by applying the principle of "route where you must, but switch where you can" and it is supported by network planning and control plane technologies.

6. Embracing the Internet

The resources of telco operators will enable billions of new users to access the Internet and they will also influence the way that users interact with the services and applications. The resulting features and functionality can be translated into significant business opportunities.

For example, NGN operators can enhance the way specific services are experienced on a subscriber-specific basis. When tools such as deep packet inspection are implemented as part of the intelligent IP edge, then service and application awareness is generated. In addition, service and session control functionality enable granular QoS and charging control. These are capabilities that cannot be replicated by Internet service providers and they can be used to differentiate the operator's value proposition.

6.1 Session control and intelligent IP Edge

Session control together with the intelligent IP edge will be the important link between the applications domain and the connectivity domain in networks where all services (operator owned or provided by third parties) are IP-based and access agnostic. This will allow network operators to manage, control and supervise the network resources and to offer service enablers to third party service and content providers.

By 2015 session control will be an extension of the functionality that is currently implemented in IMS. It will be based on SIP, but will also support emerging protocols like Extensible Messaging and Presence Protocol (XMPP), as specified by IETF.

As mentioned earlier, QoS is an important differentiator for operators since Internet services are based on the best-effort approach. In order to utilize network resources in the optimal way, policy control functions will therefore be provided to enable and control access of different applications to those resources.

Applications not directly controlled by the network operator need special attention because traditional session and policy control don't apply, however, they do have a close interest in the performance of third party services.

Their own QoS guarantees should not be impacted and at the same time they need retain control over network usage. Therefore additional functions for monitoring and controlling network resources like Deep Packet Inspection (DPI) will play an important role.

DPI functions, deployed as an integrated part of the intelligent IP edge, enable session control by providing information about session flows and network usage. Session control uses this information to allocate network resources fairly for all traffic and to guarantee the required QoS of their own services as well as those of third party business partners with whom the operator has SLAs.

6.2 Identities and trust

Tomorrow's business models will continue to be based on interactions between two partners (people, machines or service providers) and identities are required for online interactions. The need to trust a specific identity is determined by the context. For example, a nickname or chat alias may suffice for some online entertainment, but not for the electronic marketplace.

Independent identity management concepts are therefore seen as key components of tomorrow's multi-access networks. Federated identity management technologies, which allow the portability of identity information across otherwise autonomous domains, will also play an important role. The role of identities will evolve and accomplish the needs of value chains that request specific identifications, some of which may rely on trust and some on holistic identities.

Management of identities will be highly automated. Usage of networks will be service- and content-centric, requiring secure and trusted identification. Future identity management solutions will also be able to interoperate with identities provided by third parties.

Knowledge of identities will allow new advertising concepts to be developed. Network based location services can also be used to verify identities. And communication independent transaction handling and charging at the application level can enable new application types, e.g. virtual banking services.

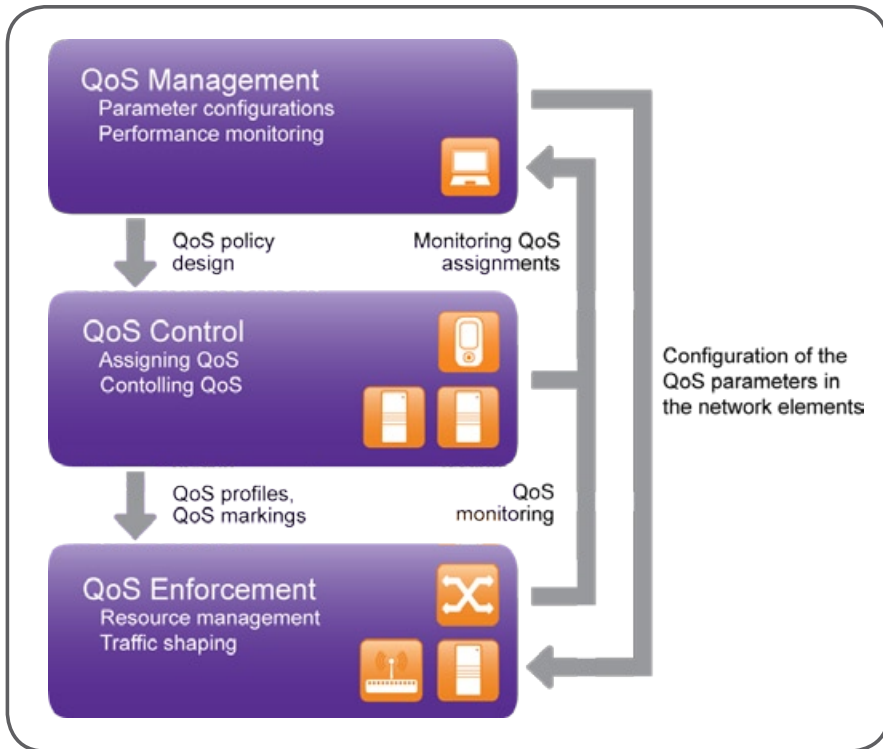

Figure 9: Quality of Service enabling elements

6.3 Internet challenges

Packet-based networks are asynchronous and this introduces some difficulties in timing and synchronization. However, timing and synchronization are essential for quality assurance, network performance, service availability and seamless inter-operability across several network elements. Wireless networks impose the most critical timing and synchronization accuracy requirements, e.g. the radio interface has very demanding frequency accuracy requirements.

A combination of solutions such as the Precision Time Protocol or Synchronous Ethernet will be deployed in future in order to meet both frequency and time synchronization requirements of all future systems.

QoS is a key parameter that is needed to support the delivery of specific, value-added services over the new networks. Delivery will be characterized by the fulfillment of several levels of service requirements supported throughout the network. We will also see different classes of supported services, which will follow their individual SLAs.

End users will have certain expectations with respect to service quality and provisioning. QoS mechanisms will be employed in order to fulfill the related Quality of Experience (QoE) criteria.

QoS differentiation concepts will be realized and monitoring and management systems will follow and deliver key performance indicators in order to control and optimize the service mix in the different parts of the networks.

In addition, operators will be able to differentiate their business by offers based on the specific QoS requirements. QoS concepts that support cost efficient and reliable end-to-end service provision will be in place by 2015.

The promise of easy access and connectivity, including application continuity, will expose carrier networks to more security threats. At the same time the possible damage caused by successful attacks against carrier networks will increase, as more and more businesses and applications will depend on these networks. Networks will therefore become an ever more sensitive target for cyber-crime and cyber-terrorism. The robustness and protection of carrier networks against such attacks will therefore be critical.

In future network security will track and anticipate the emerging threats and enable the requisite functionality. It will secure the content and identity information and allow operators to comply with global as well as regional specific regulations. This means that a network-level security architecture must be implemented. Identity management concepts and security solutions will work closely together by 2015.

7. Application Domain

As outlined earlier, the application space will transform into a market place that offers a multitude of innovative, but fragmented and specialized long tail applications. Future applications will be supported in an access independent way and the underlying software delivery framework will allow fast delivery of those applications for minimal investments.

7.1 Service Delivery Framework

The Service Delivery Framework (SDF) will provide interfaces to applications using a lightweight, IT-style framework. In addition it will follow the Service Oriented Architecture approach in order to support distributed computing and allow the easy re-use of components and functions. The SDF will also include open software development kits for third-party application and service development. We can also anticipate the opening of SDF interfaces in order to enable community participation as well as the creation of new blended services.

Web 2.0 is essentially about documented, easy-to-use APIs and rapid application development by creative individuals in the Internet space. The SDF will therefore join the Web 2.0 development process and enhance it with new global mobile communication facilities.

7.2 Operation and Business Support

Operation and business support systems is a particularly challenging area since it covers the whole network, i.e. it takes in the management of customer services over different access technologies and different devices. It also involves enabling and rolling out new applications and related business processes. Moreover, it is one of the most important areas for the operator, since it: improves operational efficiency, delivers the best possible end-user experience, and supports new revenue streams.

Service oriented management and support for lifecycle models provide a framework that has been documented and analyzed by the Tele Management Forum (TMF). Management Integration and Convergence complements the work of the TMF by

offering ways to handle operational and maintenance tasks efficiently across multi network technologies or even multi-vendor domains. In addition, the OAM concepts will adapt standards, technologies and paradigms from the IT / IETF world.

The fact that an operator's offer will embrace multiple access networks will increase network management complexity. This means that management automation in general, and self-organized networks in particular, are the only solutions that can provide the requisite functionality. Self-organized networks, which cover self-configuration, self-optimization and self-healing, allow lower-level management tasks to be automated.

As devices become more powerful and more versatile, installation, configuration and software updates will become more complex. Device management is an essential element for the "my services anywhere" paradigm. It also allows the service provider to reduce the costs associated with rolling out new services and applications by providing customer care in real time.

The growing importance of data services as sources of revenue, personalized offers and flexible tariffs represent significant challenges for operators. They result in the need for a granular segmentation of the customer base as well as a comprehensive online charging system — even for postpaid customers. Operators will therefore need to build a converged and customer-centric charge and care solution that incorporates a holistic view on all related aspects.

There will be further convergence of postpaid and prepaid charging and a move towards online charging for both categories. These emerging charging concepts will evolve and interact with identity management technologies that secure the trust levels needed for different sales channels in various markets. New revenue streams can be addressed by interlinking the charging functionality of different networks and by advertising mechanisms, e.g. sponsored access and application fees.

8. Smart connectivity

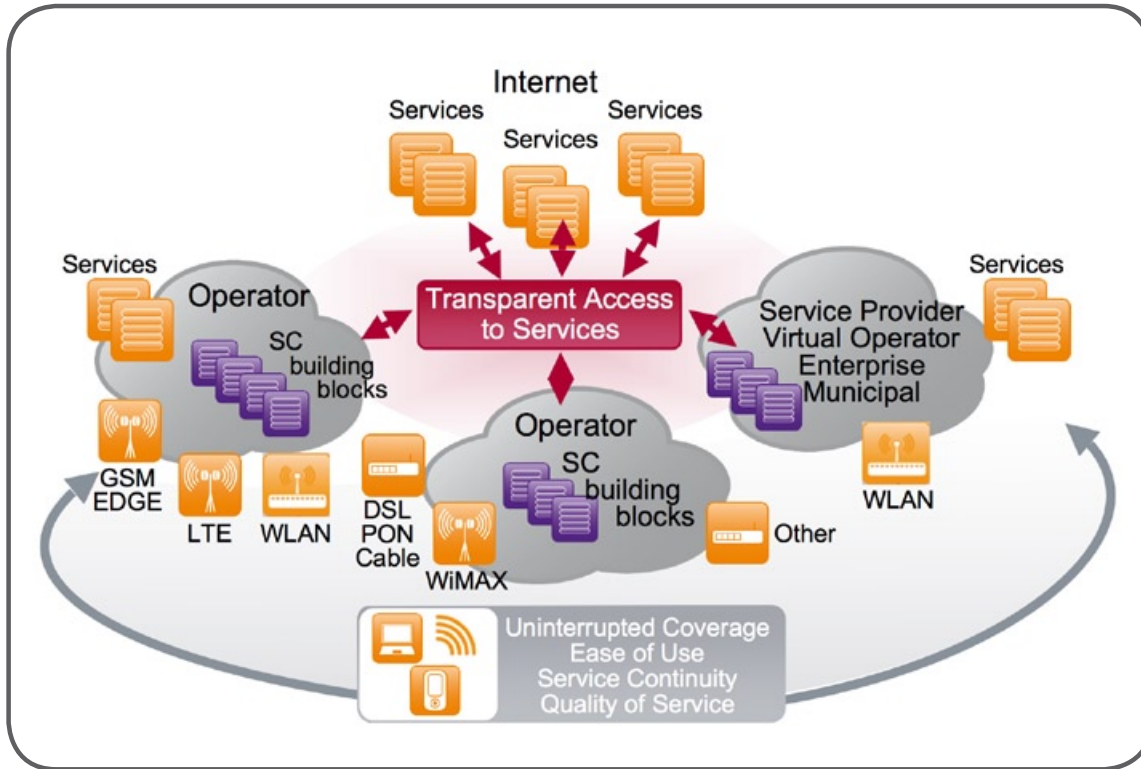

Figure 10: Smart Connectivity is an innovative concept that harnesses the power of advanced communications technology and moulds it into a unified and enhanced end user experience

Smart connectivity is an innovative, visionary concept. We see it being deployed in order to provide powerful connectivity solutions for heterogeneous networks, and it is an integral part of our network architecture vision. Smart connectivity expands on the user need for totally transparent access to network services by tying different networks and network technologies together. Service continuity is ensured while moving between different networks, managed by single or multiple stakeholders.

This concept also allows coverage and capacity extensions using preferred network technologies. It makes efficient use of legacy network investments, thereby preventing unnecessary duplication of coverage and capacity.

Ease of use is a key feature.

Smart connectivity brings user friendliness and an out-of-the-box experience into heterogeneous network environments. It enables robust access to services from any location. Usage is as easy as making a phone call because smart connectivity hides technology complexity. Thus, the user experience is optimized, churn is minimized, traffic volumes are boosted and it becomes easier to adopt new services and technologies.

Smart connectivity introduces value-added intelligence via overlay solutions, so it can be deployed in conjunction with current network technologies. We foresee the functionality being standardized in order to enable implementation on a wide range of products and allow smart connectivity intelligence to become an integral part of future networks. This will also assure device interoperability.

9. Conclusions

Huge growth opportunity, driven by content, Internet and user growth

Value capture by managing Quality of Experience and leveraging identity data

Profitable broadband delivery by simplified architecture and unified network

8. Glossary

ADSL	Asynchronous Digital Subscriber Line	IEEE	Institute of Electrical and Electronics Engineers	QoS	Quality of Service
AJAX	Asynchronous JavaScript and XML	IMS	IP Multimedia System	SAE	System Architecture Evolution
ARPU	Average Revenue per User	IP	Internet Protocol	SDF	Service Delivery Framework
ATM	Asynchronous Transfer Mode	IPTV	Internet Protocol Television	SDO	Software Defined Optics
BPEL	Business Process Execution Language	ISDN	Integrated Services Digital Network	SGSN	Serving GPRS Support Node
BRAS	Broadband Remote Access Server	ISP	Internet Service Provider	SIP	Session Initiation Protocol
BSS	Business Support System	IT	Information Technology	SLA	Service Level Agreement
CE	Carrier Ethernet	LAN	Local Area Network	SMS	Short Message Service
DPI	Deep Packet Inspection	LTE	Long Term Evolution	SOA	Service-oriented architecture
DSL	Digital Subscriber Line	MIC	Management Integration and Convergence	TAP	Terabit Access Point
DSLAM	DSL Access Multiplexer	MIMO	Multiple Input Multiple Output	TMF	Tele Management Forum
DSM	Dynamic Spectrum Management	MNO	Mobile network Operator	TV	Television
DWDM	Dense Wavelength Division Multiplexing	MSAN	Multiservice Access Node	UMA	Unlicensed Mobile Access
E-LAN	Ethernet LAN	MVNO	Mobile Virtual Network Operator	UMTS	Universal Mobile Telecommunications System
E-LINE	Ethernet Line eNodeB evolved Node B (LTE)	NG-PON	Next Generation Passive Optical Network	VDSL	Very high data rate Digital Subscriber Line
Gbps	Gigabit per second	OEO	Optical - Electrical - Optical conversation	VDSL2	2nd generation VDSL
GGSN	Gateway GPRS Support Node	OLT	Optical Line Terminal	WiFi	IEEE 802.11-based wireless local area network (WLAN)
GPON	Gigabit Passive Optical Network	OPEX	Operational Expenditure	WiMAX	Worldwide Interoperability for Microwave Access
GPRS	General Packet Radio Service	OSS	Operation Support System	WLAN	Wireless local area network
GPS	Global Positioning System	OTN	Optical Transport Network	xDSL	Digital Subscriber Line technologies
GSM	Global System for Mobile Communication	P2P	Peer-to-Peer	xDSL3	3rd generation of xDSL technologies
HDTV	High Definition television	PLC	Photonic Lightwave Circuits	XMPP	Extensible Messaging and Presence Protocol
HSPA	High Speed Packet Access	PON	Passive Optical Network		
		POTS	Plain Old Telephone Service		
		PTP	Precision Time Protocol		
		QoE	Quality of Experience		

Nokia Siemens Networks Corporation

P.O. Box 1
FI-02022 NOKIA SIEMENS NETWORKS
Finland

Visiting address:
Karaportti 3, ESPOO, Finland

Switchboard +358 71 400 4000 (Finland)
Switchboard +49 89 5159 01 (Germany)

The contents of this document are copyright © 2008 Nokia Siemens Networks. All rights reserved.

A license is hereby granted to download and print a copy of this document for personal use only. No other license to any other intellectual property rights is granted herein. Unless expressly permitted herein, reproduction, transfer, distribution or storage of part or all of the contents in any form without the prior written permission of Nokia Siemens Networks is prohibited.

The content of this document is provided "AS IS", without warranties of any kind with regards its accuracy or reliability, and specifically excluding all implied warranties, for example of merchantability, fitness for purpose, title and non-infringement. In no event shall Nokia Siemens Networks be liable for any special, indirect or consequential damages, or any damages whatsoever resulting from loss of use, data or profits, arising out of or in connection with the use of the document. Nokia Siemens Networks reserves the right to revise the document or withdraw it at any time without prior notice.

Nokia Siemens Networks and the Wave-Logo are registered trademarks of Nokia Siemens Networks. Nokia Siemens Networks product names are either trademarks or registered trademarks of Nokia Siemens Networks. Other product and company names mentioned herein may be trademarks or trade names of their respective owners.